



By **JohnDow** 
Industries

System Installation Guide

151 Snyder Avenue • Barberton, OH 44203
Toll-Free: 1-800-433-0708 • Fax: 330-753-6419
E-Mail: customerservice@euroventexhaust.com • Website: www.euroventexhaust.com

INTRODUCTION

Throughout this manual, automotive system part numbers are referenced. If you are installing a heavy-duty system, refer to this chart for the corresponding heavy-duty truck part numbers

Components	Automotive	HD-Truck
Sliding Ventilation Crab	CSA-170-75, 100	CSA-230-150
Sliding Crab Hose Reel	CAR-ALU-75FT	CSA-ARL-6
Hose Supports	ATS-75, 100	ATS-150
Tailpipe Adapters	BGT-160, 160-4	BGT-200
Rail Connecting Flange	TL-170A	TL-230A
Flange Stop	FL-170A	FL-230A
Duct Connecting Flange	FCL-170A	FCL-230A
Fan Connecting Flange	FCA-170A	FCA-230A
Aluminum Rail	ALU-13	ALU-13HD

IMPORTANT

UPON COMPLETION OF INSTALLATION, FILL OUT THE ATTACHED WARRANTY ACTIVATION FORM. COMPLETING THIS FORM AND RETURNING IT TO JOHNDOW INDUSTRIES INITIATES THE WARRANTY START DATE.

MOUNTING DIMENSIONS/TOOLS REQUIREMENTS

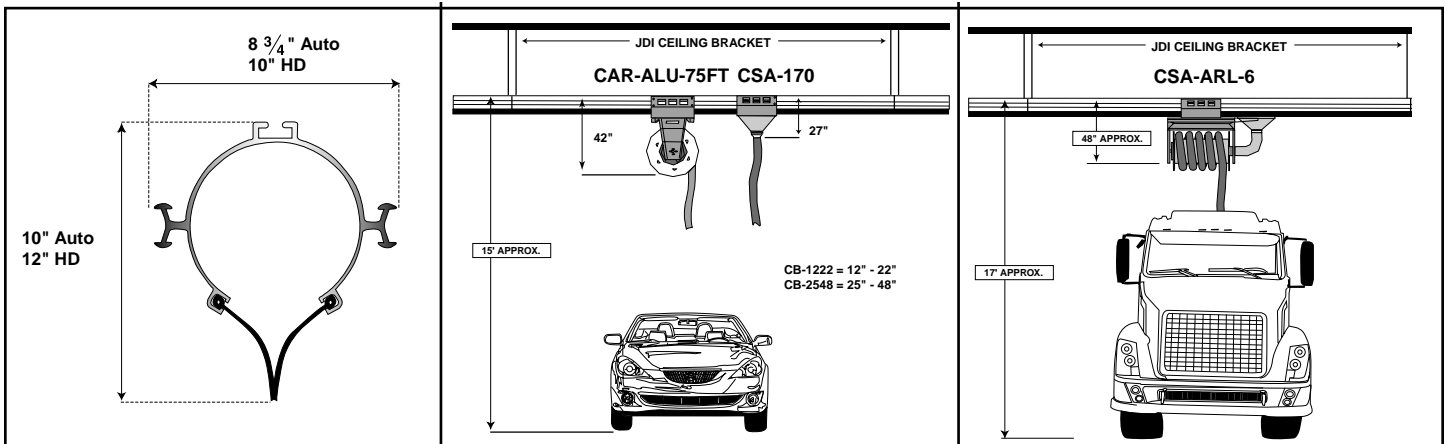

HD = Heavy-Duty System; CSA-ARL-6

Auto = Automotive System; CSA-170-75/100, CAR-ALU-75FT

REQUIRED TOOLS:

1. JohnDow Seal Insertion Tool - Contact a factory representative at 1-800-433-0708.
2. Silicone Spray
3. 1/2" Socket - Required for rail connecting flanges, fan and duct connection flanges.
9/16" Socket - Required for mounting brackets
4. 7/16" Drill Bit - Drilling mounting brackets
5. Window Clamps - Recommended for attaching ceiling brackets to roof supports
6. Clear Caulk - Caulk all rail, fan and duct connections.
7. EuroVent Seal Kit - For patching any seal seams (Supplied by JohnDow).

INSTALLATION RECOMMENDATIONS:

1. System must be adequately sealed to meet performance requirements.
2. Rail mounted fans should have a flexible connection on the outlet (To minimize vibration).
3. Remote mounted fans should have a flexible connection on the inlet and the outlet (To minimize vibration).
4. Comply with local code requirements.
5. Stackheads (roof exhaust) have no pressure loss; they should be used on roof fan exhaust points.
6. Wall exhaust points should terminate with a louver and bird/insect screen.
7. Do not locate exhaust termination points near any fresh-air intakes.
8. A duct section with an access door should be installed as close as possible to the fan inlet. This aids in the inspection of foreign materials being sucked into the fan inlet.

Step 1. Mount Ceiling Brackets to Roof Supports

- Drill holes in ceiling brackets at required location to achieve desired rail height. Assemble ceiling brackets. **DO NOT** drill through any roofing structure.
- Fasten ceiling brackets to roof supports using window clamps or other acceptable method.
- Ceiling brackets/supports should be spaced at 13' intervals at/or near each rail connection.

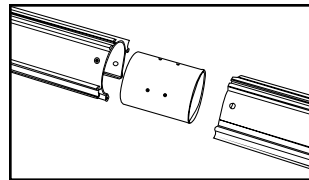

Fig. 1 TL-170A connectors

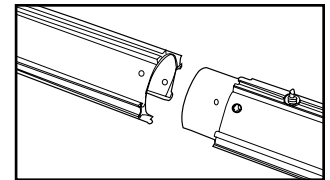

Fig. 2 Align holes and secure with bolts.

Step 2. Attach Rail to Mounting Brackets

(See "Mounting Brackets" section of Planning Guide for additional information)

- Connect the aluminum rails together using the TL-170A connecting flange with the bolts provided. (Note: For long runs it may be easier to connect rails together in lengths that can be easily handled. Unconnected sections can be joined after the rail has been attached to mounting brackets.)
- Make sure the welded section of the connecting flange is located in the open part of the rail.
- Tighten all bolts.
- Slide threaded inserts into the slots on top of the rail. See Fig. 8a & 8b. (Note: It may be helpful to insert a screwdriver at the bolt head to keep it stationary.)
- Position inserts near or at the rail connector. (Note: Two inserts are required for each EuroVent supplied bracket.)
- Attach rail to the brackets using the nuts and bolts provided. See Fig. 9.
- Check the rail for slope. Use additional washers to level the rail where necessary.
- Caulk all connection seams.

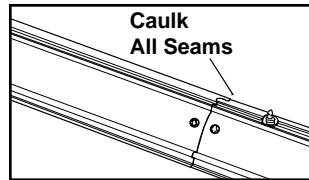

Fig. 3 Caulk all seams

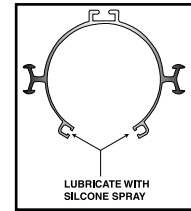

Fig. 4

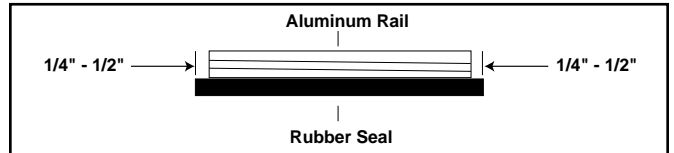

Fig. 5

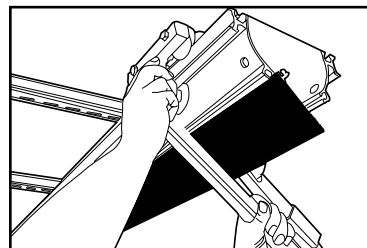

Fig. 6 Use extrusion tool to press neoprene seal into the rail.

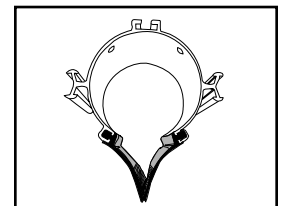

Fig. 7 When properly installed the ribbed side of the seal is on the inside of the rail and the seals forms a "V" shape at the bottom.

Step 3. Install Neoprene Seals on Rail

(Note: Installing the neoprene seal is quicker and easier once the rail has been mounted.)

*A special seal installation tool is available, on loan, from the factory. Contact a factory representative for details.

- Lubricate the lower hollow, the length of the entire rail with silicone spray. See Fig. 4
- Unroll neoprene seal. Press 6" into the rail and use neoprene insertion tool to insert the remainder. Notch overhang as shown. See Fig. 5
- Repeat this procedure for the other side of the rail. Be careful not to stretch the seal. See Fig. 7
- The ribbed side of the seal should be installed facing each other so that it is not visible.

(Note: The longer the rail run without a gap in the seal is best. Where seal sections are joined, close the resulting gap in the seals with the seal kit provided.)

Step 4. Mount Sliding Hosereels & Sliding Crab(s) Onto the Rail

- From open end of the rail, mount the sliding crab so the top wheels ride on the upper hollow in the rail and bottom wheels ride on the lower hollow in the rail. See Fig. 10.
- The vent slot inside the crab should be between the neoprene seals.
- Note: If using the BK5 balancer, install the balancer to the sliding crab and then mount the crab onto the rail. (For crabs only)

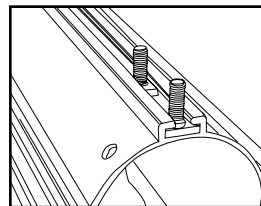

Fig. 8a Slide insert bolts into top slot on the rail. Inserts can be moved to any position along the rail.

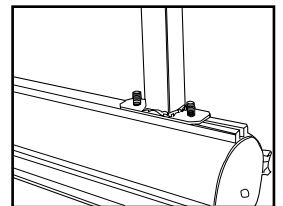

Fig. 9 Attach rail to mounting bracket.

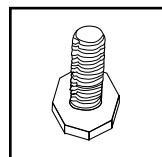

Fig. 8b Insert mounting bolt

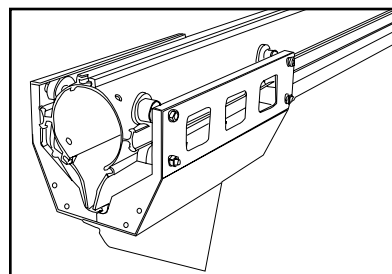

Fig. 10 Mount the sliding crab onto the rail.

Step 5. Install the Flange Stop

- On the end of the rail opposite the end where the fan will be mounted, install the FL-170 flanged stop.
- Slide the flanged stop into the rail aligning the holes. See Fig. 11.
- Attach using the bolts provided.
- Note: Depending on how the fan is mounted to the system, more than one FL-170 flanged stop may be required.
- Caulk between flanged stop and rail.

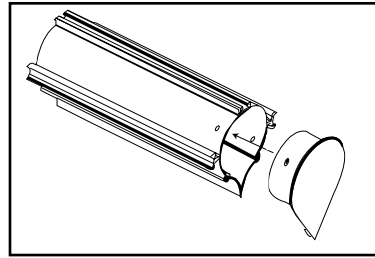

Fig. 11 Flange stop fits into one end of the rail and is attached with the bolts provided.

Step 6. Install the Exhaust Fan

There are three basic methods for attaching the exhaust fan to the EuroVent system.

Method 1. - Fan Mounted to the Aluminum Rail

For this method, be sure to order the fan - specifying that it will be rail mounted. The fan will be shipped with the FCA-170A fan connecting flange already attached.

- Position the fan with the mounted flange into the rail aligning the holes. See Fig. 12.
- Fasten using the bolts provided.
- Caulk between fan flange, rail and fan.

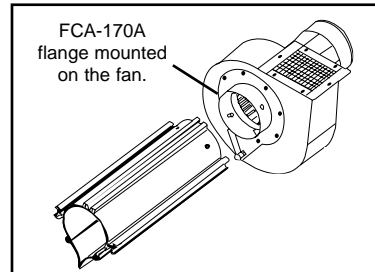

Fig. 12 The exhaust fan can be mounted directly to the rail using the FCA-170A connecting flange. Flange comes mounted to the fan when fan is ordered with the SP suffix.

Method 2. - End of Rail - Remote Mounted Fan

Typically this method incorporates the exhaust fan mounted on a platform either inside or outside of the building. Ducting is then run from the end of the rail to the fan.

For this method the fan comes with mounting feet so it can be attached to a platform or other structure to hold the fan. The installer should plan on providing the platform and any ducting that is required to run from the fan to the rail.

- On the end of the rail nearest the fan, install the FCL-170A duct connecting flange by sliding the flange into the rail and aligning the holes. See Fig. 13.
- Attach using the bolts provided.
- Fasten the fan on the platform and connect the required ducting.
- Caulk all seams, fan/duct connections.

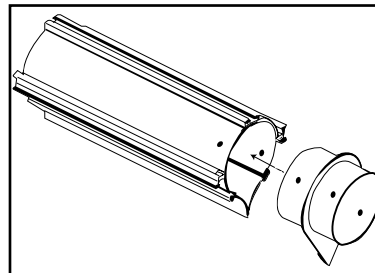

Fig. 13 For a remote mounted fan a FCL-170A duct connector is needed to connect ducting from the rail to the fan.

Method 3. - Center of Rail - Remote Mounted Fan

In some cases, the efficient design of the system requires the fan to be positioned in the center of the rail and not on either end. The fan is typically mounted using the same method as in Method 2 above. A BC-360 series duct connection nozzle is required to allow the ducting to be connected from the center rail to the fan.

Note: When assembling rail sections, remember to place the 3' rail section where ducting will be placed. (Usually installed in the center of the EuroVent run.)

- Position the duct into the cut out section of the rail and drill four holes through the duct flange and into the rail large enough to accept a self tapping screw.
- Remove the duct and spread a bead of silicone sealer around the outside of the opening.
- Re-position the duct into the hole and attach it with the screws.
- Mount the fan on the platform and connect the required ducting.
- Caulk perimeter of BC series duct and rail section.

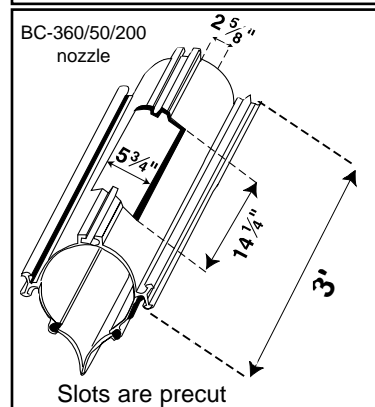
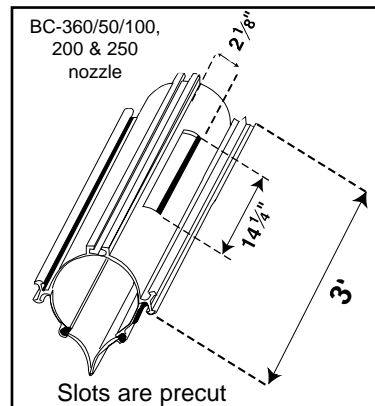

Figs. 14A and 14B A BC-360 series duct connection nozzle is needed when the exhaust fan is connected to the middle of the system.

Step 7. Installation of Sliding Crab CSA-170-75, 100 & 150, Exhaust Hose, Tailpipe Adapters & Hose Supports

- Cut exhaust hose to required length and attach to the sliding crab nozzle with a clamp. See Fig. 15.
- Attach tailpipe adapter(s) to the other end of the hose with a clamp. See Fig. 16.
- Attach a hose support assembly to each hose. Hose supports should be positioned on the exhaust hose to allow the hose to hang off of the floor at a level that is easily accessible to the user but out of the way. See Figs. 17 and 18.
- Install hose stops on each hose and tighten with hose clamps. See Fig. 19.
- Install pull handles (if ordered) where shown. See Fig.20.

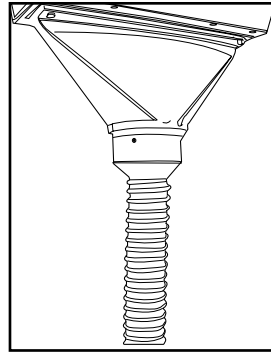

Fig 15 Connect the exhaust hose to the sliding crab with the hose clamp provided.

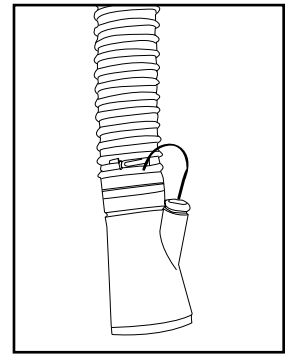

Fig 16 Connect the tailpipe adapter to the end of the exhaust hose with the clamp provided.

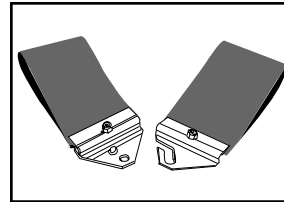

Fig 17 ATS series hose support assembly

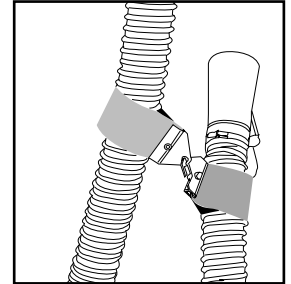

Fig 18 Position the ATS hose support to the exhaust hose. Position supports so hose will hang off of the floor.

Step 8. Connect Remaining Ducting and Vents and Wire Fan to Electrical Supply

Connect any remaining ducting i.e. from fan to outside vent.

The exhaust fan can now be connected to the electrical supply by a certified electrician and according to local building codes.

Any on/off switches, wiring, etc are supplies by the electrical contractor. See Fig. 21.

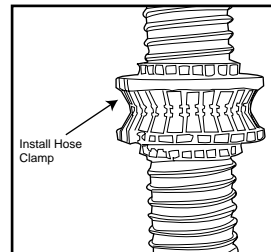

Fig 19

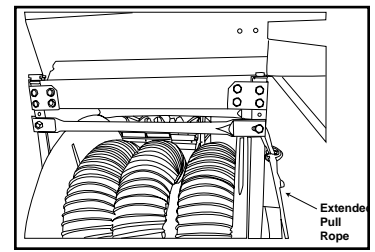

Fig 20

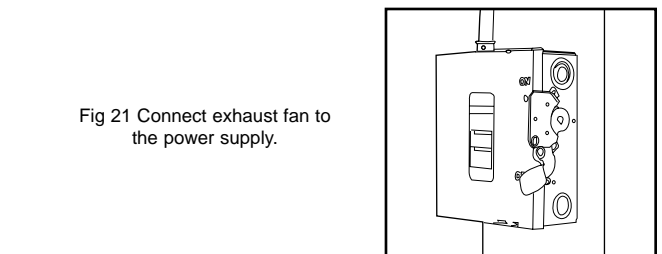
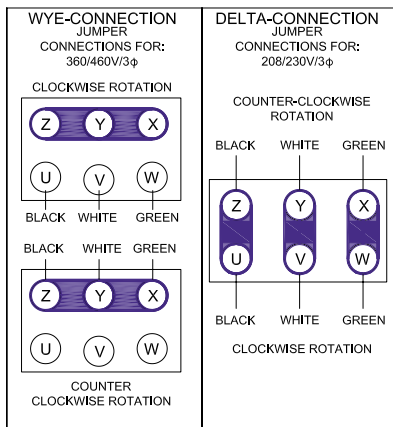

Fig 21 Connect exhaust fan to the power supply.

**For Assistance Phone Toll-Free
1-800-433-0708**

JohnDow Industries

**JohnDow Industries, Inc.
151 Snyder Ave.
Barberton, OH 44203**



WARRANTY ACTIVATION FORM

JOB NAME: _____

JOB LOCATION: _____

INSTALLATION DATE: _____

INSTALLATION CONTRACTOR: _____

FAN MODEL NO.: _____

MOTOR MFGR: _____

VOLTAGE: _____

MOTOR MODEL NO.: _____

AMPS: _____

RPM: _____

MEASURED VOLTAGE: _____

MEASURED AMPS: _____

OVERLOAD RATING: _____

**PLEASE FAX TO JOHNDOW INDUSTRIES: 330-753-6419
OR MAIL TO THE ADDRESS BELOW.**

151 Snyder Avenue • Barberton, OH 44203, USA
Phone: 1-800-433-0708 • Fax: 330-753-6895

E-mail: customerservice@euroventexhaust.com • Web: www.euroventexhaust.com



SUGGESTION/COMMENTS

At JohnDow Industries, customer satisfaction is important. We value your business and would like to develop a long term relationship with you and your establishment. We have attached this form so that you can share your thoughts with us and have value added impact into our products and services.

Thank you for choosing JohnDow Industries to serve your exhaust extraction requirements.

JOB NAME: _____

JOB LOCATION: _____

INSTALLATION DATE: _____

INSTALLATION CONTRACTOR: _____

SUGGESTIONS/COMMENTS: _____

151 Snyder Avenue • Barberton, OH 44203, USA
Phone: 1-800-433-0708 • Fax: 330-753-6895

E-mail: customerservice@euroventexhaust.com • Web: www.euroventexhaust.com